

## Bucket Forks Assembly Instructions

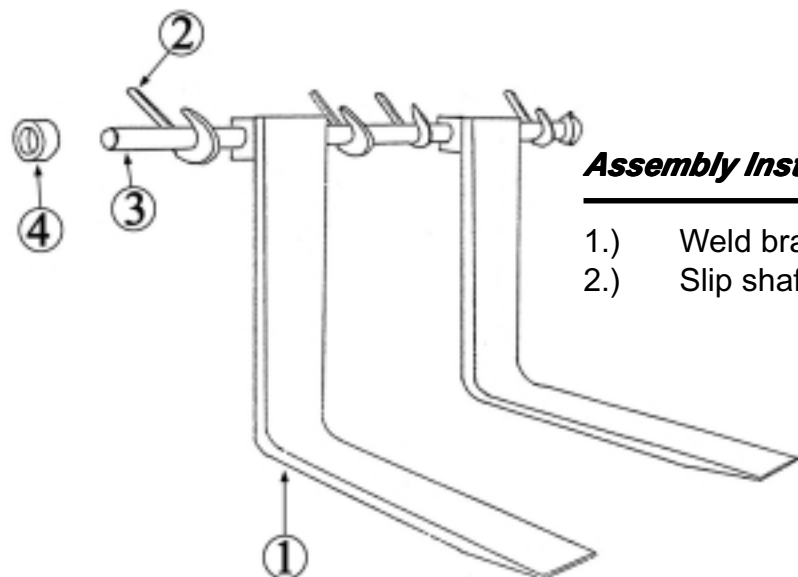
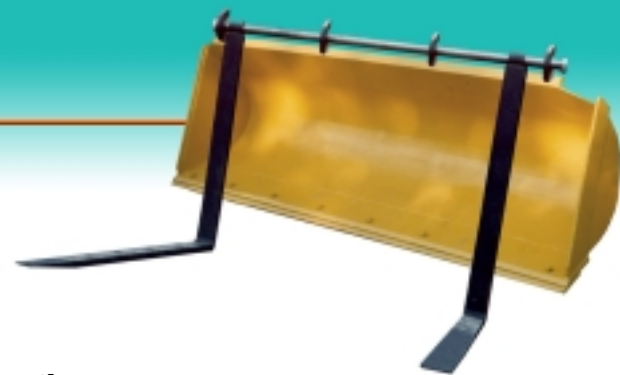

### Assembly Instructions:

- 1.) Weld brackets on spill guard (bracket spacing variable).
- 2.) Slip shaft and tines into brackets.

#	Description	Qty.
1	Tine Assembly	(2)
2	Brackets	(4)
3	Shaft	(1)
4	Locking Collars	(2)

## FLECO Attachments Warranty

**I. PROPRIETARY INFORMATION** - Any specification, drawings, designs, manufacturing data and/or other information transmitted to Buyer in connection with the performance of this order are the property of the Seller and are disclosed in confidence upon the condition that they are not to be produced or copied or used for furnishing information or equipment to others, or for any other purpose detrimental to the interest of the Seller.

**II. PRICES** - Prices are F.O.B. point of manufacture of shipment. Unless otherwise set forth, the Buyer agrees to pay all expenses including, but not limited to, transportation, handling, insurance, sales, excise and other applicable taxes levied on Buyer or FLECO Attachments in conjunction with this sale.

**III. CANCELLATION AND CHANGES** - Changes made in the specifications shall be valid only if in writing signed by authorized representatives of the Buyer and FLECO Attachments. FLECO Attachments reserves the right to charge Buyer with any additional expense caused by changes in any order. Changes made in shipping schedules or complete cancellation must be requested in writing. All such changes may be subject to charges imposed by the manufacturer, or may be refused altogether.

**IV. RETURNS** - No items may be returned to FLECO Attachments without written approval and shipping instructions. All returns are subject to charges which will vary in accordance with the conditions, e.g. standard or special product, stocking or non-stocking items, quality, etc.

**V. APPROVAL OF ORDERS** - Any contract resulting from a quotation is subject to approval by FLECO Attachments in writing. Any purchase order acknowledgment submitted by Buyer shall be deemed to constitute a confirmation and acceptance of the terms and conditions of this quotation, even if such document states terms additional to or different terms contained in any document submitted to FLECO Attachments by Buyer. Signature by FLECO on Buyer's purchase order acknowledgment form does not constitute acceptance of or agreement to any terms and conditions in addition to or different from those contained herein, but shall constitute only acknowledgment of receipt of such document.

### VI. LIMITED WARRANTY AND DISCLAIMER

A. Equipment manufactured by FLECO Attachments is warranted to be free from defects in materials or workmanship for a period of one (1) year from the date such products are shipped to the Buyer.

B. This warranty shall terminate in the event of alteration made or commenced by a party other than FLECO Attachments without prior written approval of FLECO Attachments.

EXCEPT AS SPECIFICALLY PROVIDED ABOVE IN VIA, FLECO Attachments DISCLAIMS ANY AND ALL EXPRESS AND IMPLIED WARRANTIES WITHOUT RESPECT TO OR IN ANY WAY RELATING TO EQUIPMENT, INCLUDING WITHOUT LIMITATION THE WARRANTY OF MERCHANTABILITY AND THE WARRANTY OF FITNESS FOR A PARTICULAR PURPOSE.

### VII. LIMITATION OF LIABILITY AND REMEDIES

A. The liabilities of FLECO Attachments under its warranty in VIA & B shall be strictly and exclusively limited to furnishing materials required for repair or replacement provided prompt notification in writing is given to FLECO Attachments.

B. FLECO Attachments shall not be liable or responsible for CONSEQUENTIAL DAMAGES OR INCIDENTAL DAMAGES for any cause arising out of or in connection with this agreement, including, but not limited to, downtime, overhead, labor, damage to machinery, interruption or spoiled production, loss of profit, accident or injury.

**VIII. LITERATURE** - FLECO Attachments assumes no liability as to the accuracy of content of any advertising material or reference material. Advertising materials are submitted solely for the purpose of illustration and do not constitute any term of the proposal or sale.

**IX. ERRORS** - FLECO Attachments reserves the right to correct any typographical or clerical errors which may be present in the prices, specifications, or acknowledgment.

**X. DELAYS** - FLECO Attachments shall not be responsible for delays in delivery or any other non-performance of this agreement due to causes beyond its control, labor disputes or any other similar or dissimilar causes including, but not limited to, transportation availability, material shortages, or delay in delivery or failure to deliver by FLECO Attachments's suppliers.

**XI. SHORTAGES** - No claim for shortage or error will be considered unless submitted in writing to FLECO Attachments within ten (10) days after receipt of shipment by Buyer.

**XII. SAFETY** - The Buyer agrees to indemnify FLECO Attachments and save FLECO Attachments harmless from any liability or obligation incurred by FLECO Attachments to persons injured directly or indirectly in connection with the installation, maintenance, or operation of the equipment sold hereunder because of the Buyer's negligent installation, maintenance or operation of the equipment, or because of the lack of devices on the equipment to protect personnel from injury while the equipment is in operation whether or not required by law or regulations of government bodies having jurisdiction.

**XIII. WAIVER** - There are not rights, warranties, or conditions expressed or implied, statutory or otherwise, other than those herein contained. This agreement contains the entire agreement between Buyer and FLECO Attachments and can be modified or rescinded only in writing signed by both parties. No waiver of an provision of this agreement shall be binding unless in writing signed by an authorized representative of the party against whom the waiver is asserted, and, unless expressly made generally applicable, shall only apply to the specific case for which the waiver is given. Failure of either party to insist upon strict performance of this agreement shall not be construed as a waiver of any terms and conditions thereof.

**IV. COMPLIANCE WITH LAWS** - Buyer, except as stated in Section XIII above, shall be responsible for compliance with the provisions of all federal, state and local laws and regulations, the violation of which may result in liability to Buyer, including the Fair Labor Standards Act of 1938 as amended. This order shall not be considered to be a subcontract under any government contract unless the Buyer specifically so states in writing. In such event, the Buyer and FLECO agree to negotiate as to the terms and conditions in addition to the above which shall be included in such government contract.

**XV. APPLICABLE LAW** - Any contract resulting from this quotation shall be governed by the laws of the State of Ohio.



# INSTRUCTION GUIDE

For Blade Rakes, Thumbs,  
Grapples, & Bucket Forks

## Blade Rake Mounting Instructions

A.) Center rake on moldboard, positioning bottom beam 1/4" up from bottom of cutting edge.

B.) Install mounting brackets & weld brackets in place (some bracket trimming may be needed). See below for bracket positions.

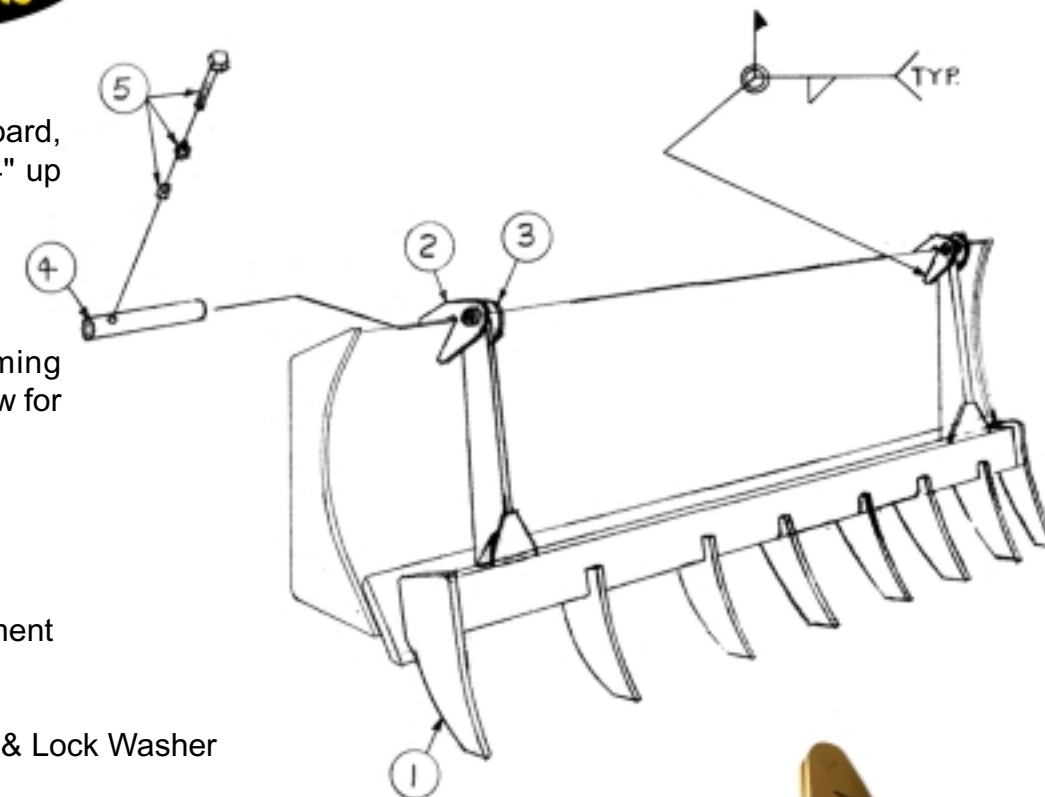

### PARTS:

- 1.) Rake Weldment
- 2.) Mounting Bracket Weldment
- 3.) Mounting Bracket
- 4.) Pin
- 5.) 1/2" x 4" Hex Bolt w/Nut & Lock Washer

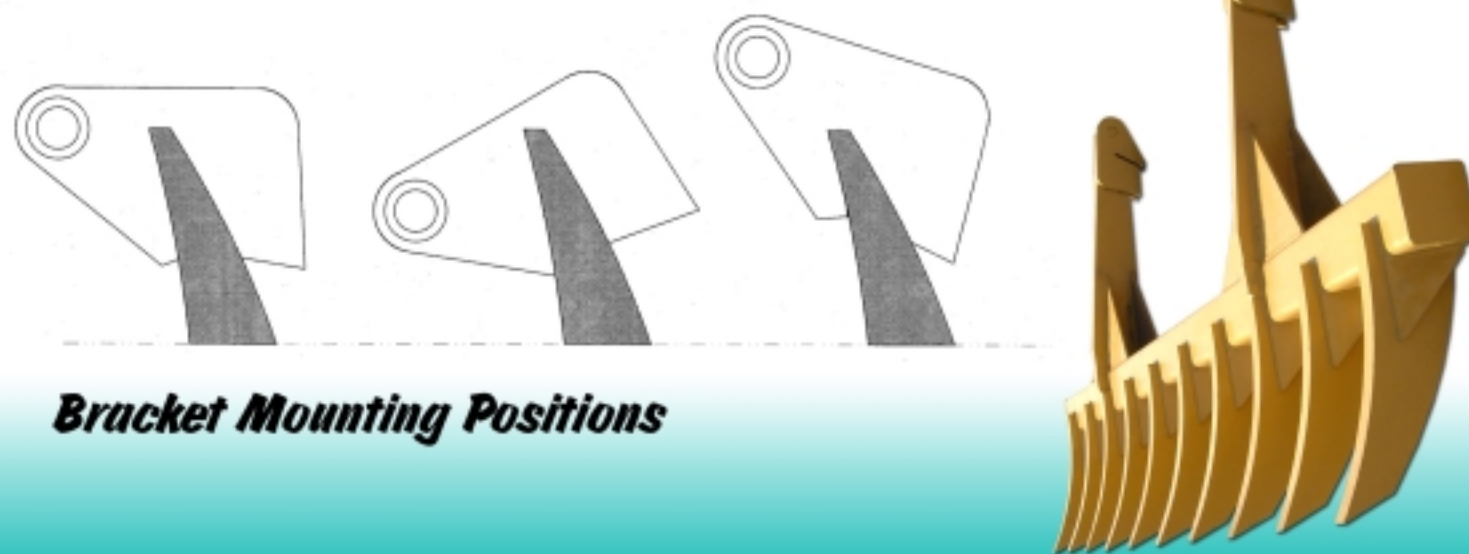

## Bracket Mounting Positions

10290 Stringfellow Road • St. James City, FL 33956 • (888) 577-9695 • (239) 283-7366 fax



## Mechanical Thumb Welding Instructions

Use the following instructions when installing thumb attachments

Locate the thumb mounting bracket as close as possible to the bucket pivot. Allow 1/2" clearance with bucket in full curl position.

### Welding Specifications

All welding and practices to be in accordance with the American Welding Society.

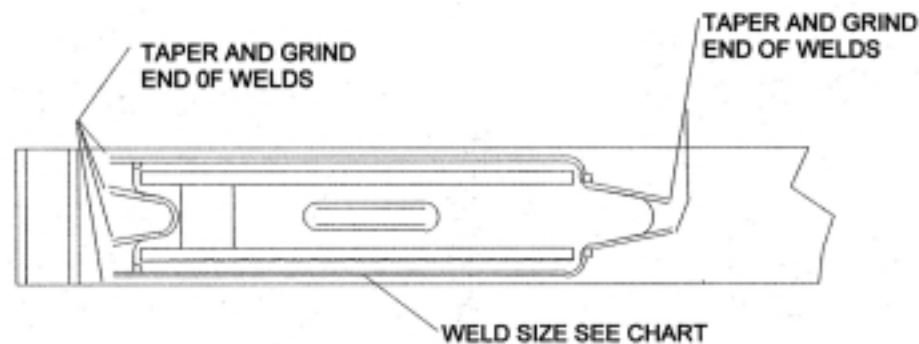
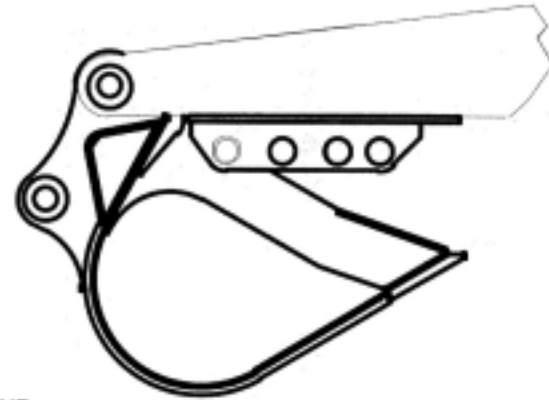

### Weld Size

The weld size based on the thinnest material that is being welded.

Thinnest Material Size	Single Fillet
1/2"	7/16"
3/4"	1/2"
1"	3/4"
1-1/2"	1"

Weld electrode and procedure is as follows: weld using E7018 or equivalent electrode. All welding to be performed by a qualified or certified welder. See the bracket welding for detailed instructions. Welding to be peened and the end of each weld ground and tapered to eliminate weld stress and stress risers.

## Hydraulic Thumb Welding Instructions

### When boom is wider than bracket

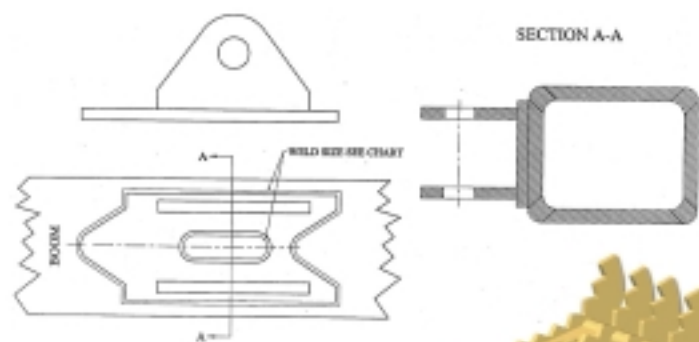

### When boom is more narrow than bracket

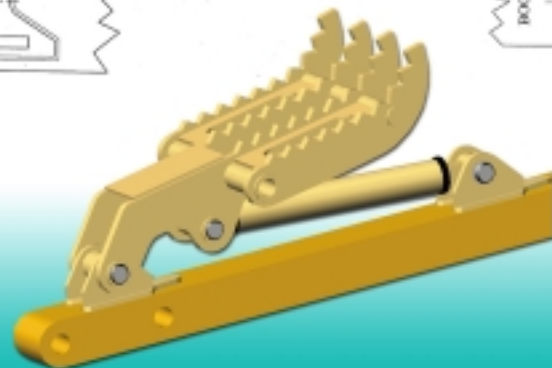
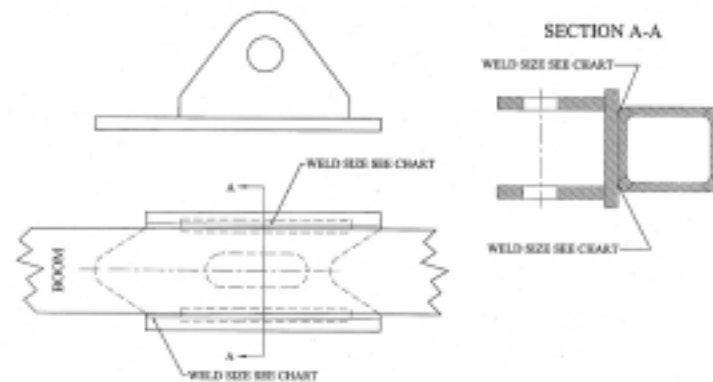

## Thumb Folding Instructions

### 12" x 40" Thumb

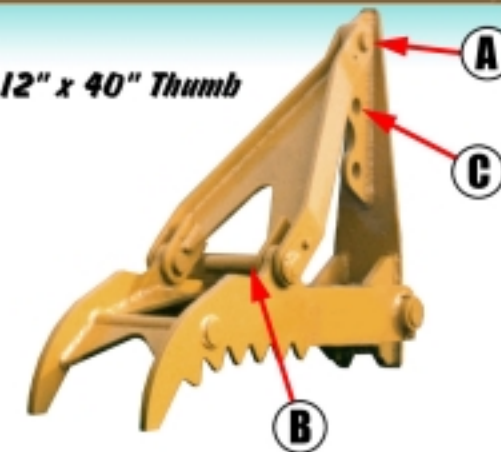

- 1.) Remove pin (A).
- 2.) Pull pin (B) 3/4 way out.
- 3.) Rotate main thumb up to mounting bracket and secure by inserting pin (B) through position (C).
- 4.) Replace pin (A).



- 1.) Remove pin (A).
- 2.) Pull pin (B) half way out.
- 3.) Rotate main thumb up to mounting bracket and secure by inserting pin (B) through position (C).
- 4.) Replace pin (A).

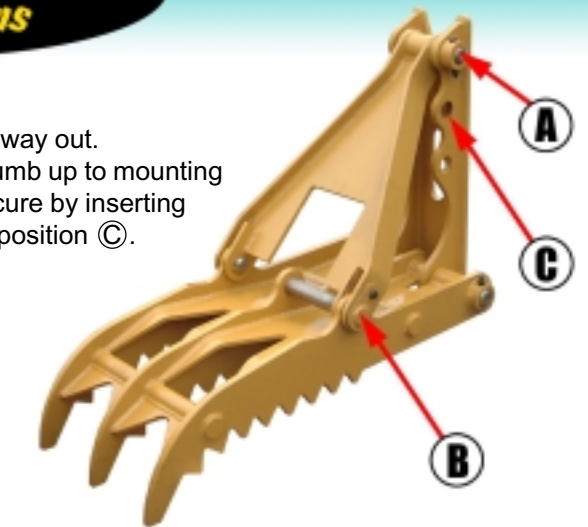

collapsed position

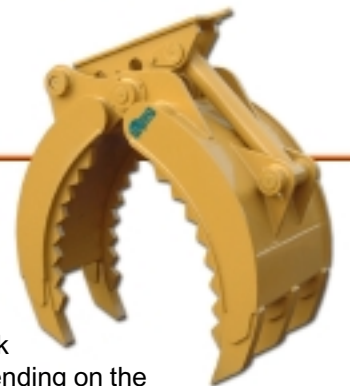

## Excavator Grapple Installation

- 1.) Don't remove both pins at the same time.
- 2.) Attach the grapple to the hydraulic and main bucket pins.
- 3.) Place dipper stick in a vertical position with grapple hanging below.
- 4.) Using hydraulics, angle the grapple approx. 35° from vertical position toward the cab.

- 5.) Place the stiff arm in the top hole of the grapple and the bottom hole on the mounting plate.

- 6.) Tack-weld mounting plate to stick by following the diagrams below depending on the unit you are installing. Gently open and close until grapple is satisfactory for application.

- 7.) Stitch weld mounting plate.

- 8.) Grease often

